

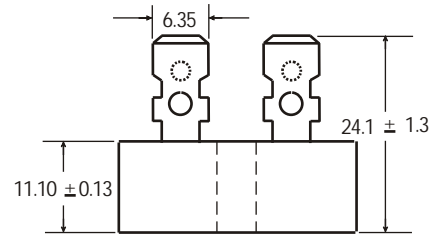

Features

- This series is UL listed under the Recognized Component Index
- The plastic material used carries Underwriters Laboratory flammability recognition 94V-0
- Universal 4-way terminals, snap-on, wrap-around, solder or P.C. Board mounting
- Surge overload ratings to 400 amperes
- Electrically isolated metal case for maximum heat dissipation
- Case to terminal isolation voltage 2500V

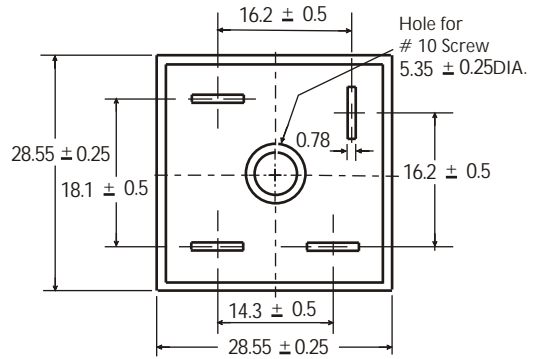

Dimensions in millimeters (1mm=0.0394")

Mechanical Data

Case: Metal case
 Terminals: Plated .25"(6.35mm) Faston
 Weight: 1.116 ounce, 31.6 grams (approx)
 Mounting Position: Bolt down with silicone thermal compound between bridge and mounting surface for maximum heat transfer efficiency
 Mounting Torque: 20 in-lb max.

Maximum Ratings & Thermal Characteristics

Rating at 25°C ambient temperature unless otherwise specified, Resistive or Inductive load, 60 Hz.
 For Capacitive load derate current by 20%.

Parameter	Symbol	KBPC 50005	KBPC 5001	KBPC 5002	KBPC 5004	KBPC 5006	KBPC 5008	KBPC 5010	unit
Maximum repetitive peak reverse voltage	VRRM	50	100	200	400	600	800	1000	V
Maximum RMS bridge input voltage	VRMS	35	70	140	280	420	560	700	V
Maximum DC blocking voltage	VDC	50	100	200	400	600	800	1000	V
Maximum average forward rectified output current at TA=40°C	IF(AV)	50							A
Peak forward surge current single sine-wave superimposed on rated load (JEDEC Method)	IFSM	400							A
Rating for fusing (t<8.3ms)	I ² t	664							A ² sec
Typical thermal resistance per element(1)	ReJA	2.5							°C / W
Operating junction and storage temperature range	TJ, TSTG	-55 to + 150							°C

Electrical Characteristics

Rating at 25°C ambient temperature unless otherwise specified. Resistive or Inductive load, 60Hz.
 For Capacitive load derate by 20 %.

Parameter	Symbol	KBPC 50005	KBPC 5001	KBPC 5002	KBPC 5004	KBPC 5006	KBPC 5008	KBPC 5010	Unit
Maximum instantaneous forward voltage drop per leg at 25.0A	VF	1.0							V
Maximum DC reverse current at rated TA =25°C DC blocking voltage per element TA =125°C	IR	10 500							µA

Notes: (1)Thermal resistance from Junction to Ambient on P.C.board mounting.

Rating and Characteristic Curves ($T_A=25^{\circ}\text{C}$ Unless otherwise noted)
KBPC50005 thru KBPC5010

Fig. 1 Derating Curve for Output Rectified Current

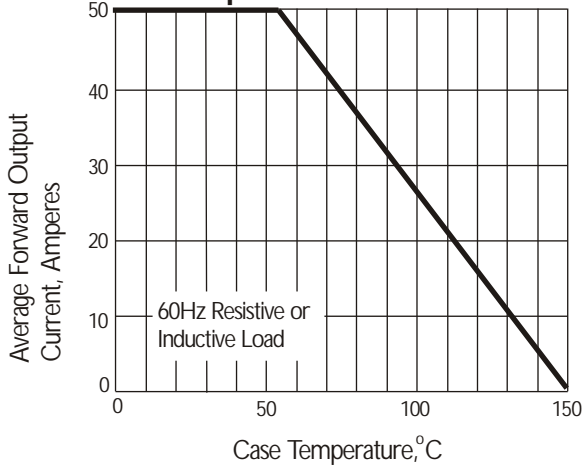

Fig. 2 Maximum Non-repetitive Peak Forward Surge Current

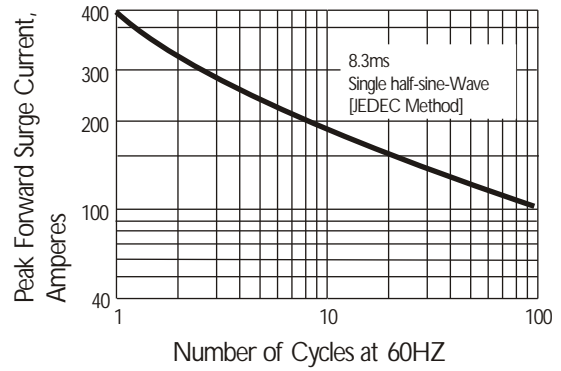

Fig. 3 Typical Instantaneous Forward Characteristics

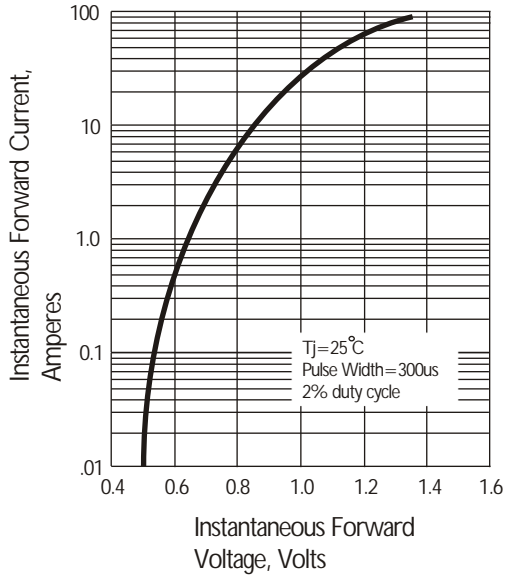

Fig. 4 Typical Reverse Characteristics at $T_J=25^{\circ}\text{C}$

